

Datenblatt  
Data sheet  
Fiche technique

# ESSH 3021 DV25

ESSH 3021 DV25\_001

Rev.	001
Datum Date	03/10/2020

A-A ( 1 : 25 ) Master

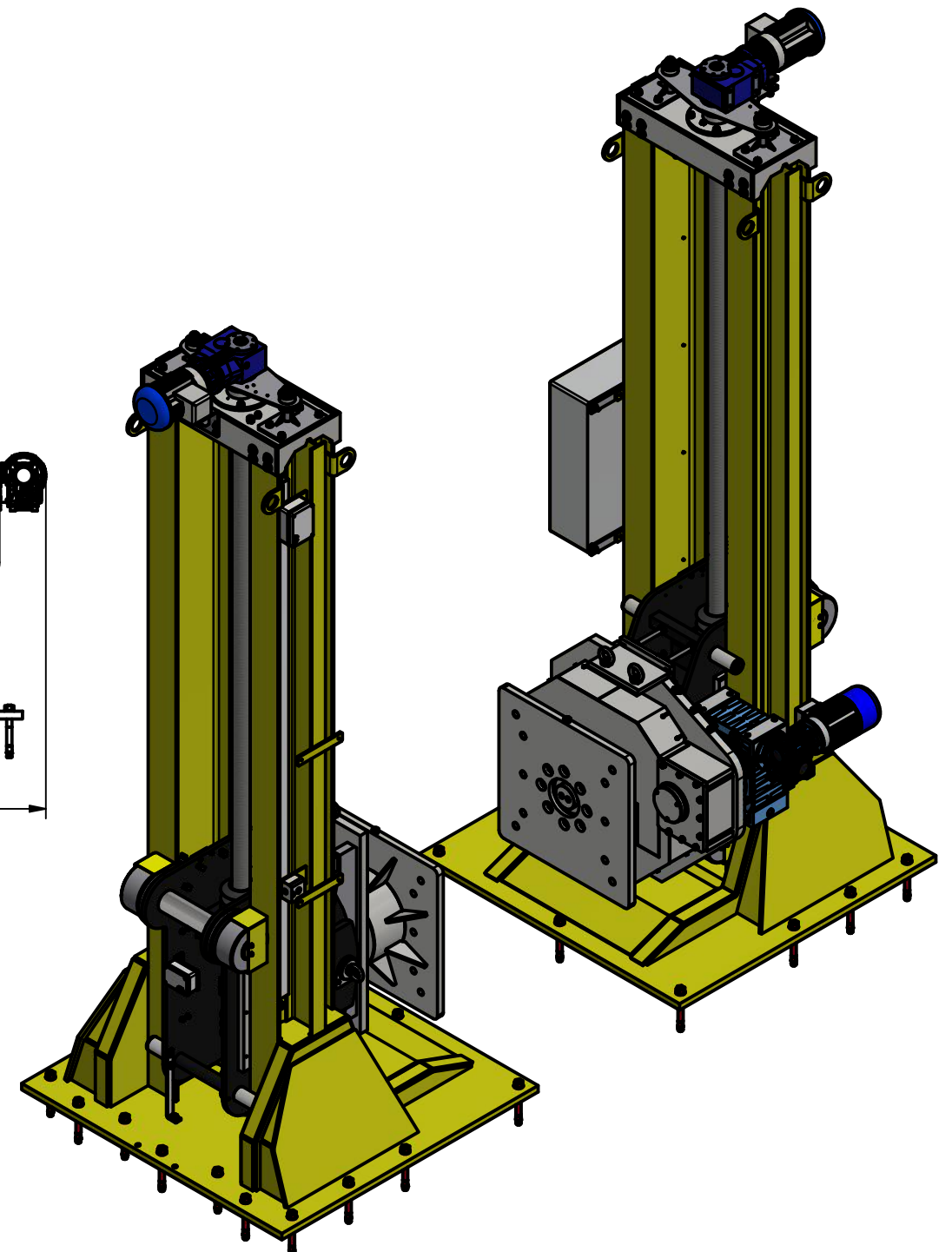
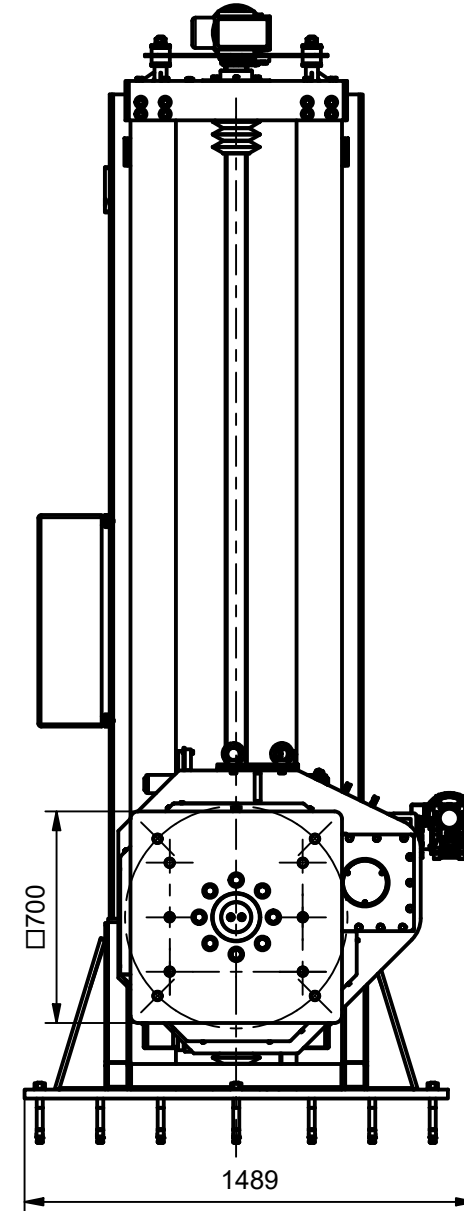
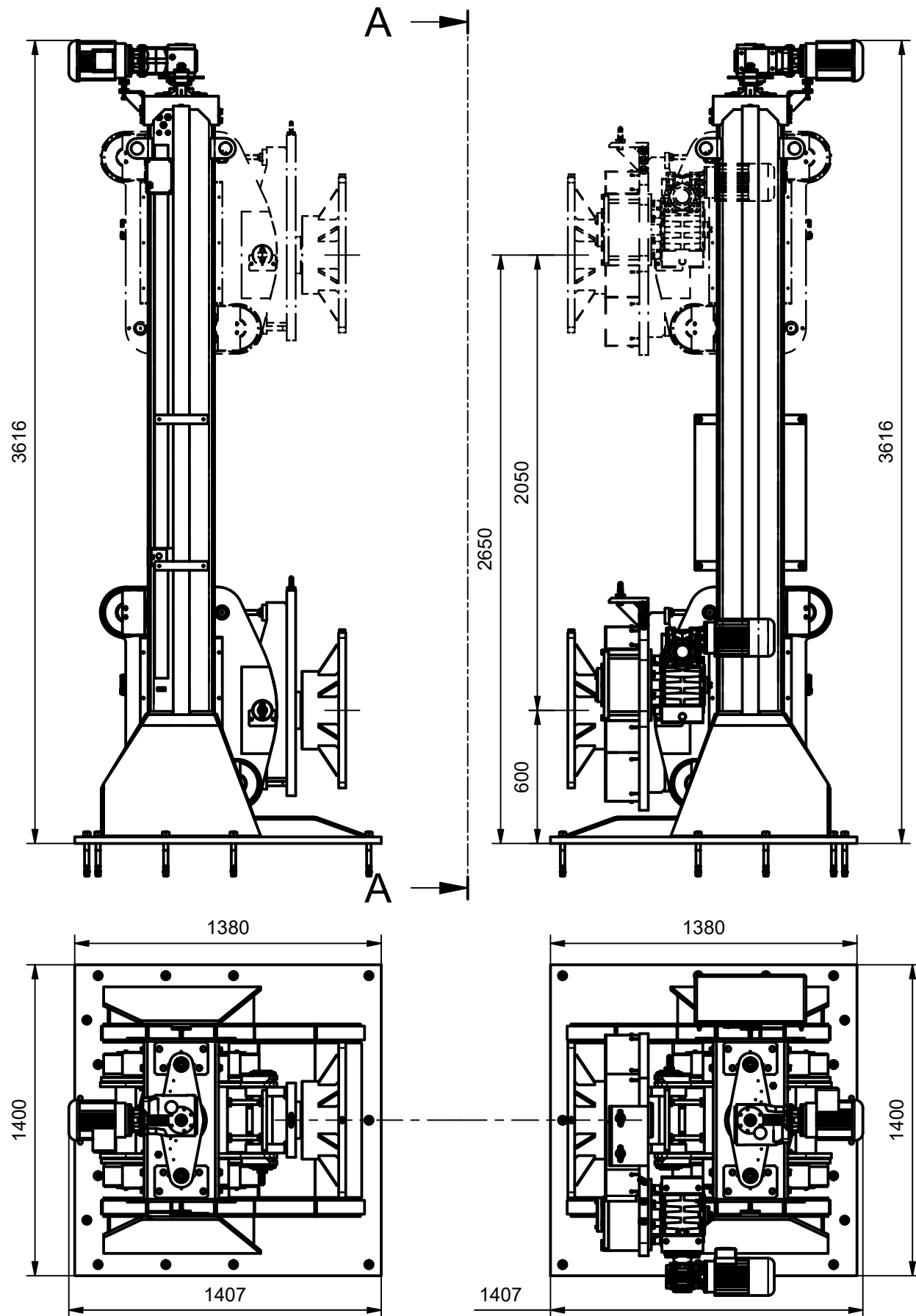

Standard flange plate  
Standard Flanschplatte  
Plaque á bride standard  
( 1 : 5 )

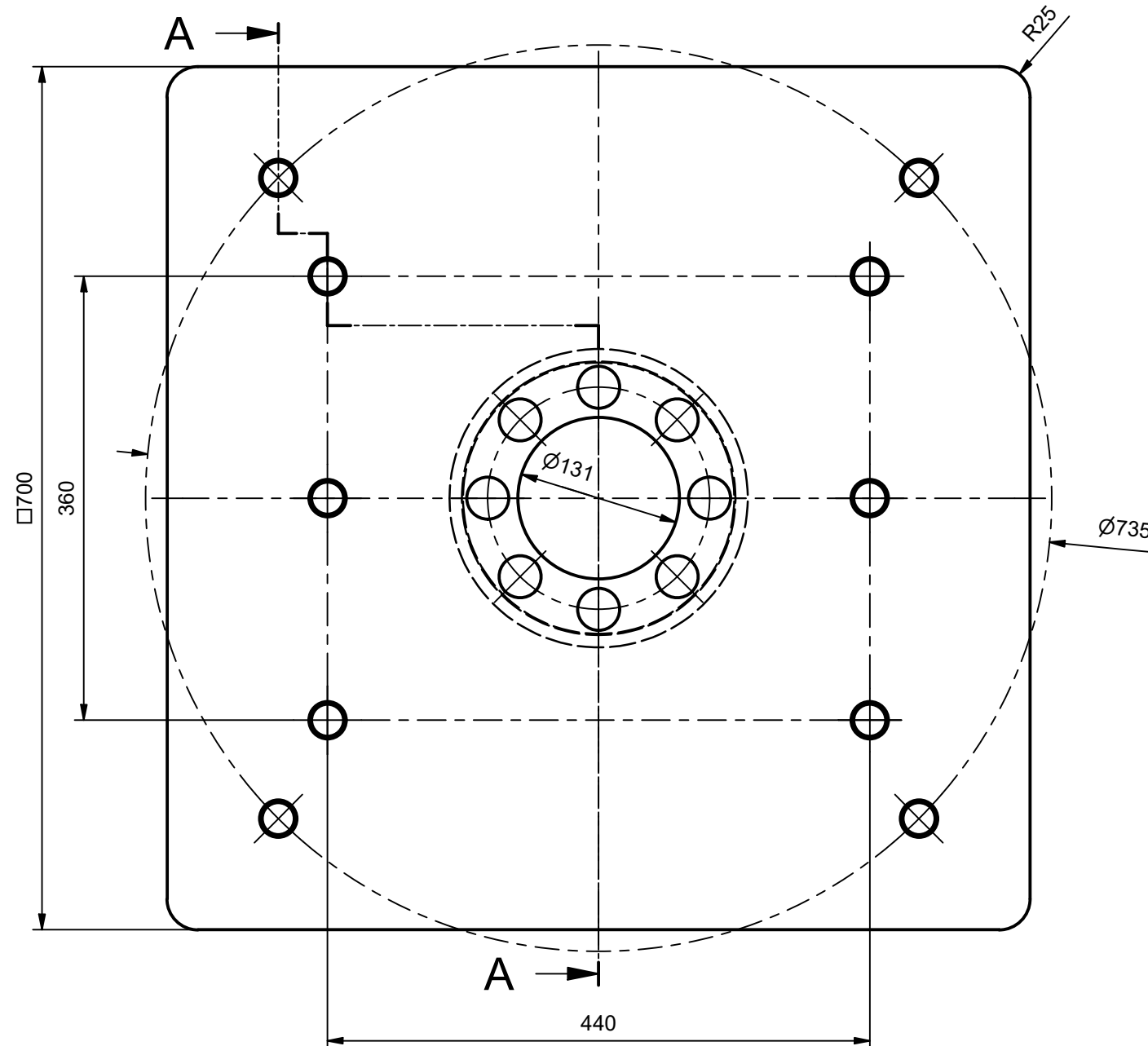

A-A ( 1 : 5 )

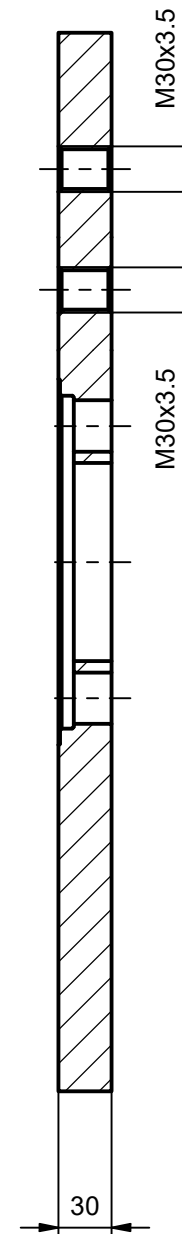

Leistungsdaten Performance data Caractéristiques	
DATA	WERT VALUE VALUER
Tragkraft Lifting capacity Capacité	2 x 15tons = 30tons
Drehmoment Turning moment Couple de rotation	25.000Nm
Hubgeschwindigkeit Lifting speed Vitesse de levage	300mm/min
Drehgeschwindigkeit Turning speed Vitesse de rotation	0,42rpm
Benötigte Leistung Required power Puissance requise	2 x 4kW 3x400V / 50Hz

