

Rev.	001
Datum Date	21/09/2020

A-A (1 : 20)
Master

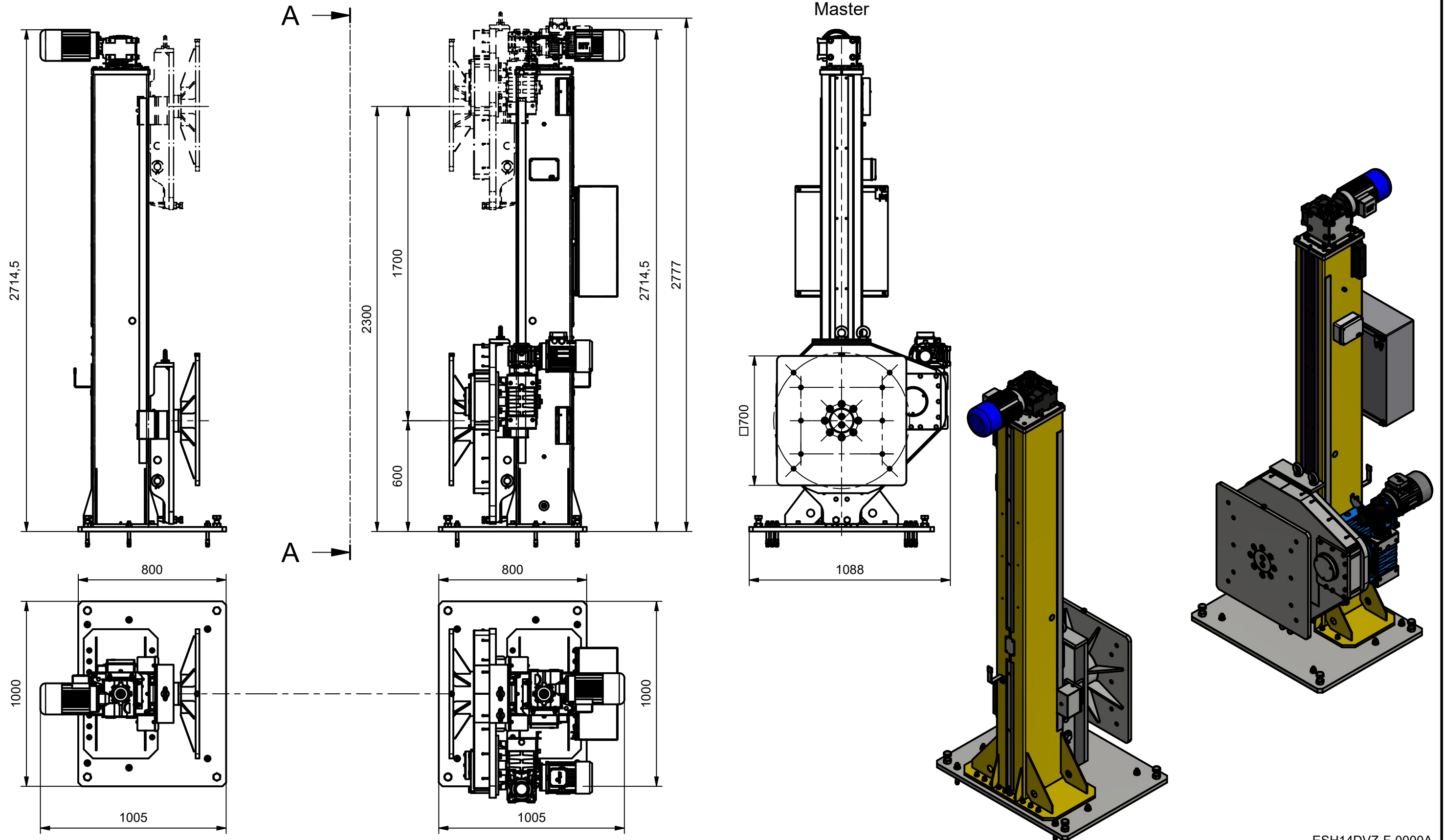

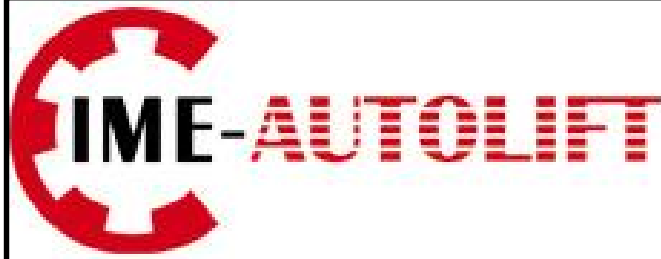

Datenblatt
Data sheet
Fiche technique

ESH 0821 DV10

ESH 0821 DV10_002

Rev.	001
Datum Date	21/09/2020

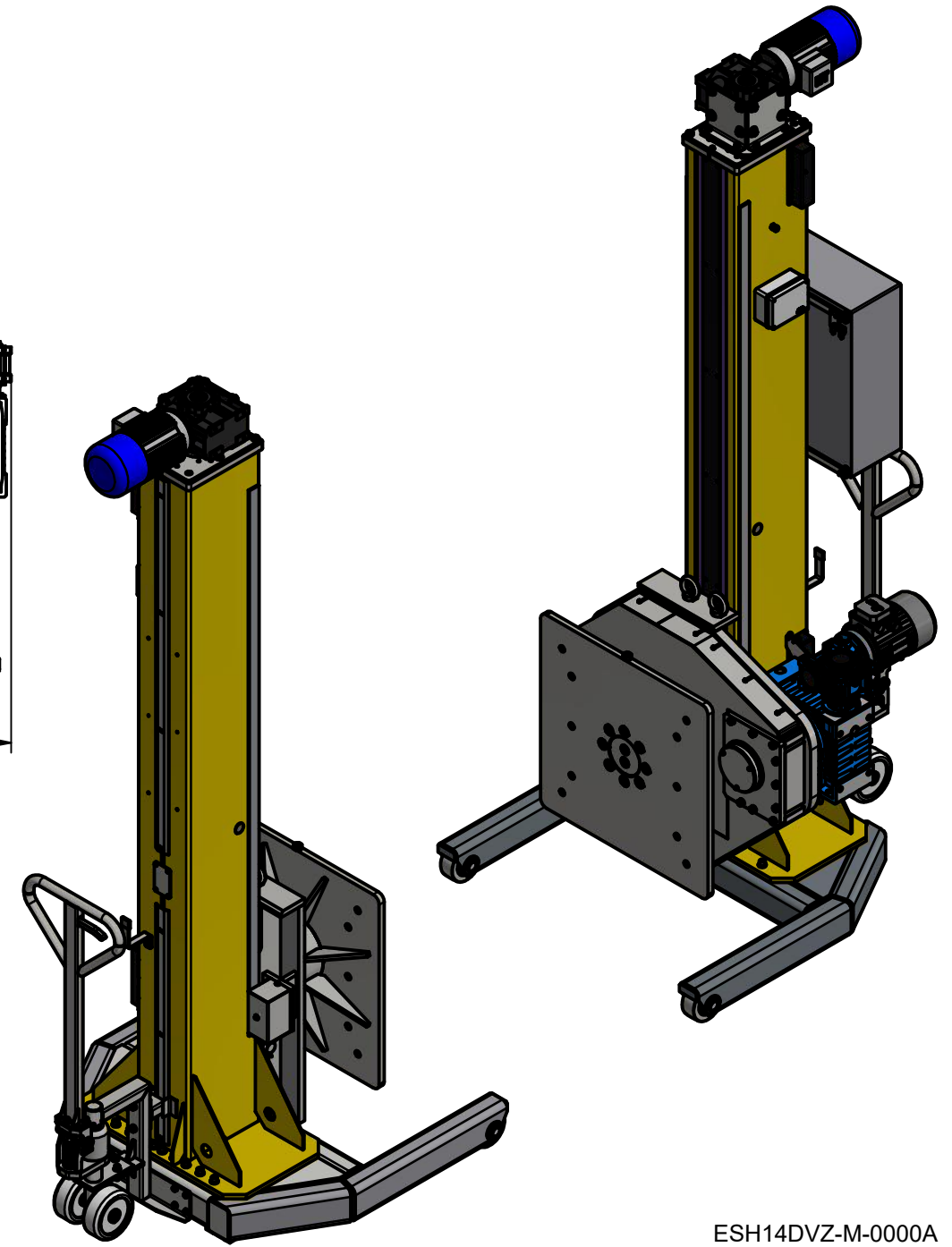
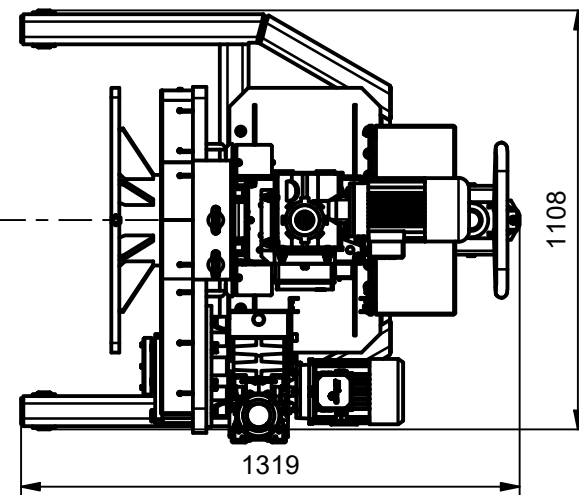
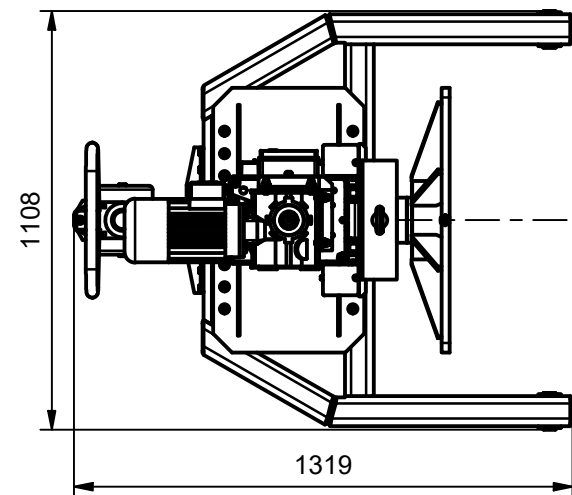
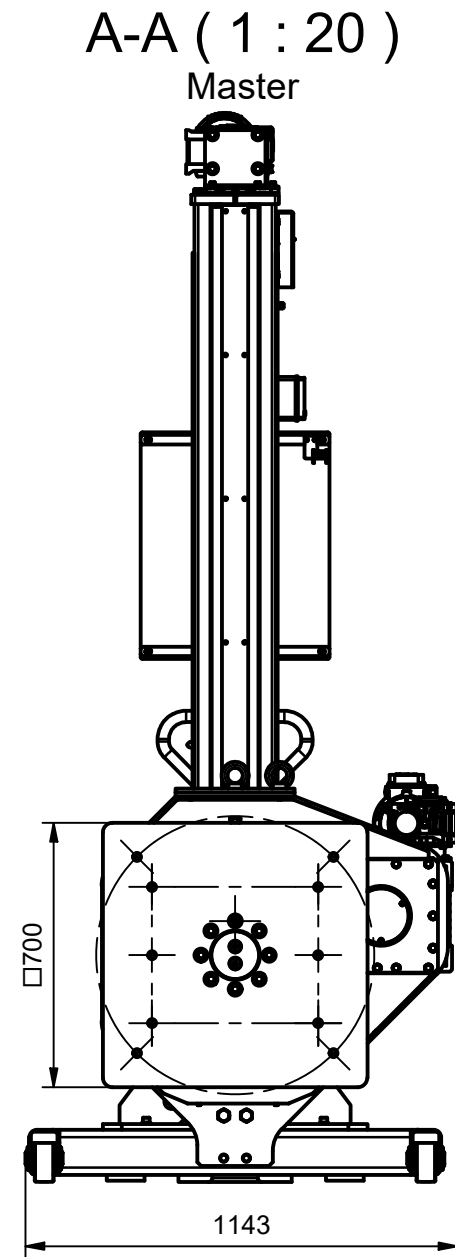
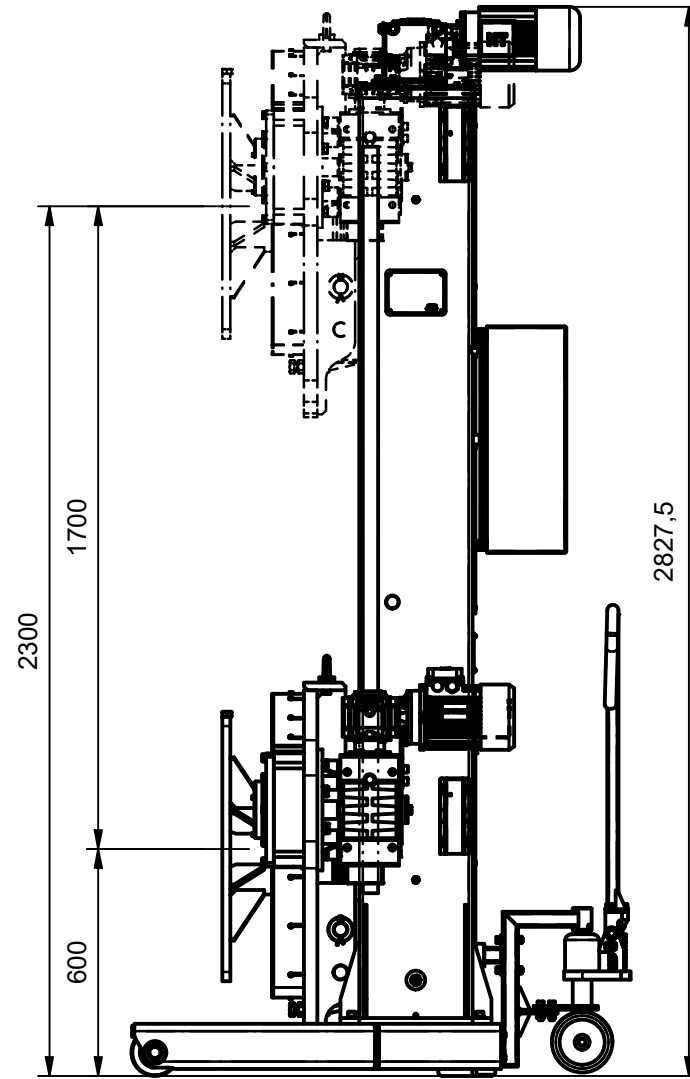
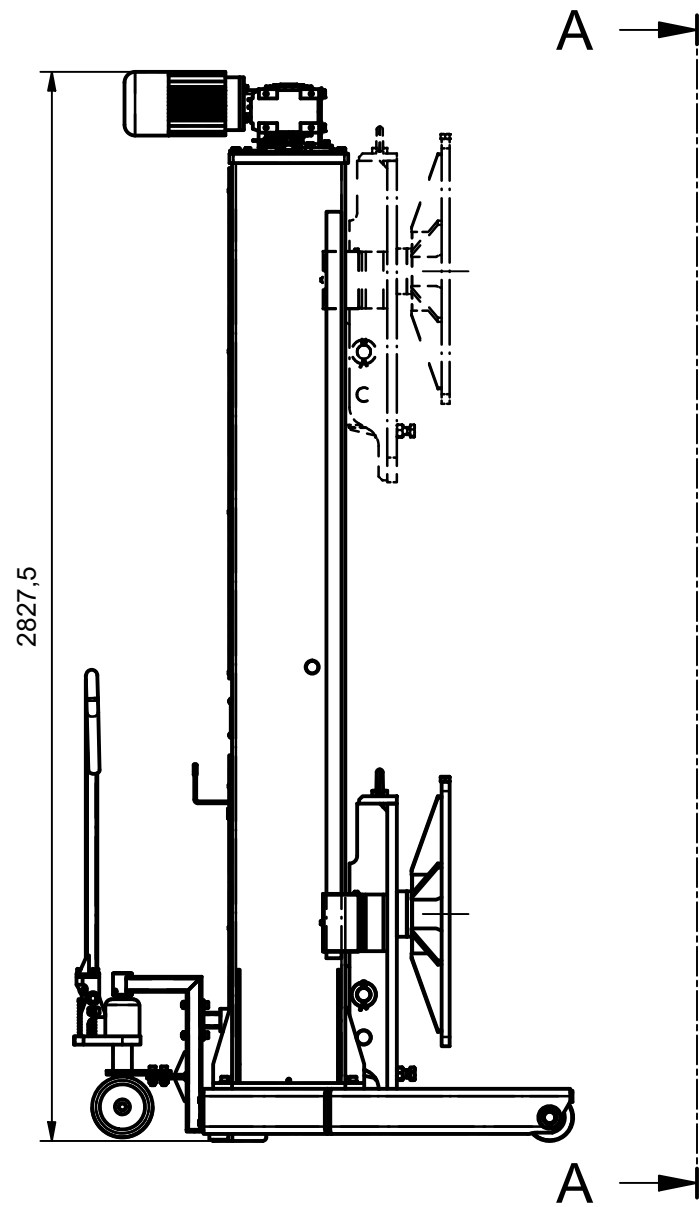

Standard flange plate
Standard Flanschplatte
Plaque à bride standard
(1 : 5)

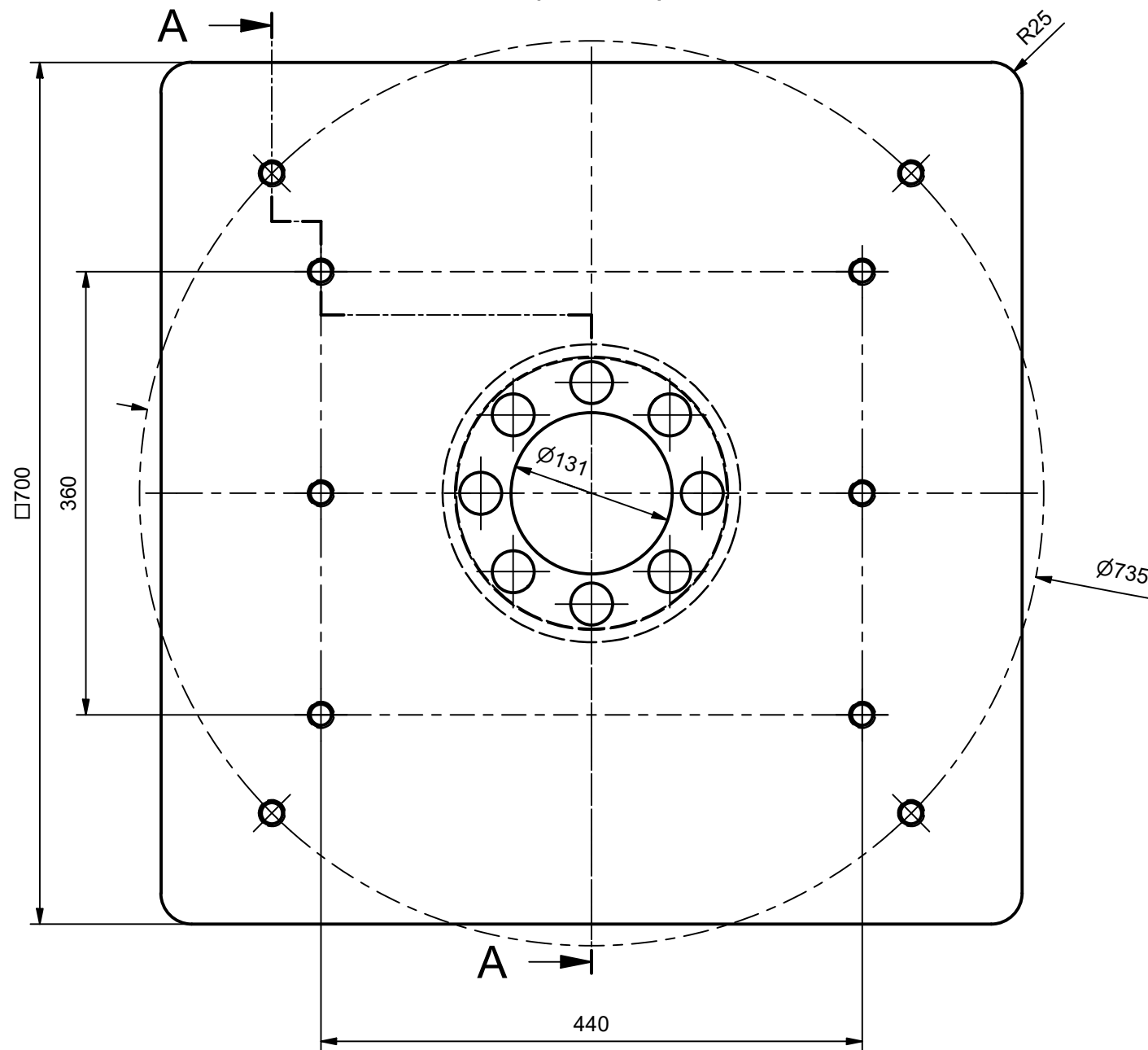

A-A (1 : 5)

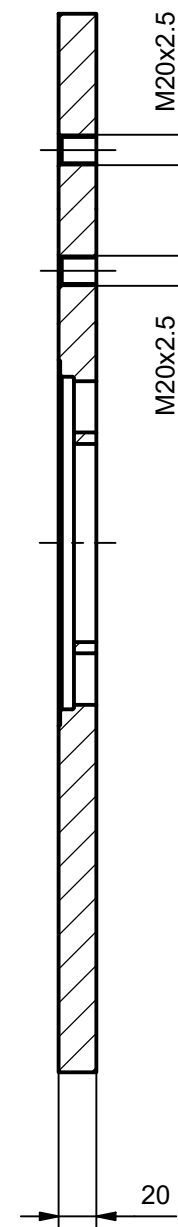

Leistungsdaten Performance data Caractéristiques	
DATA	WERT VALUE VALUER
Tragkraft Lifting capacity Capacité	2 x 4tons = 8tons
Drehmoment Turning moment Couple de rotation	10.000Nm
Hubgeschwindigkeit Lifting speed Vitesse de levage	560mm/min
Drehgeschwindigkeit Turning speed Vitesse de rotation	0,42rpm
Benötigte Leistung Required power Puissance requise	2 x 2,2kW 3 x 400V / 50Hz

