

Rev.	001
Datum Date	21/09/2020

A-A (1 : 20)
Master

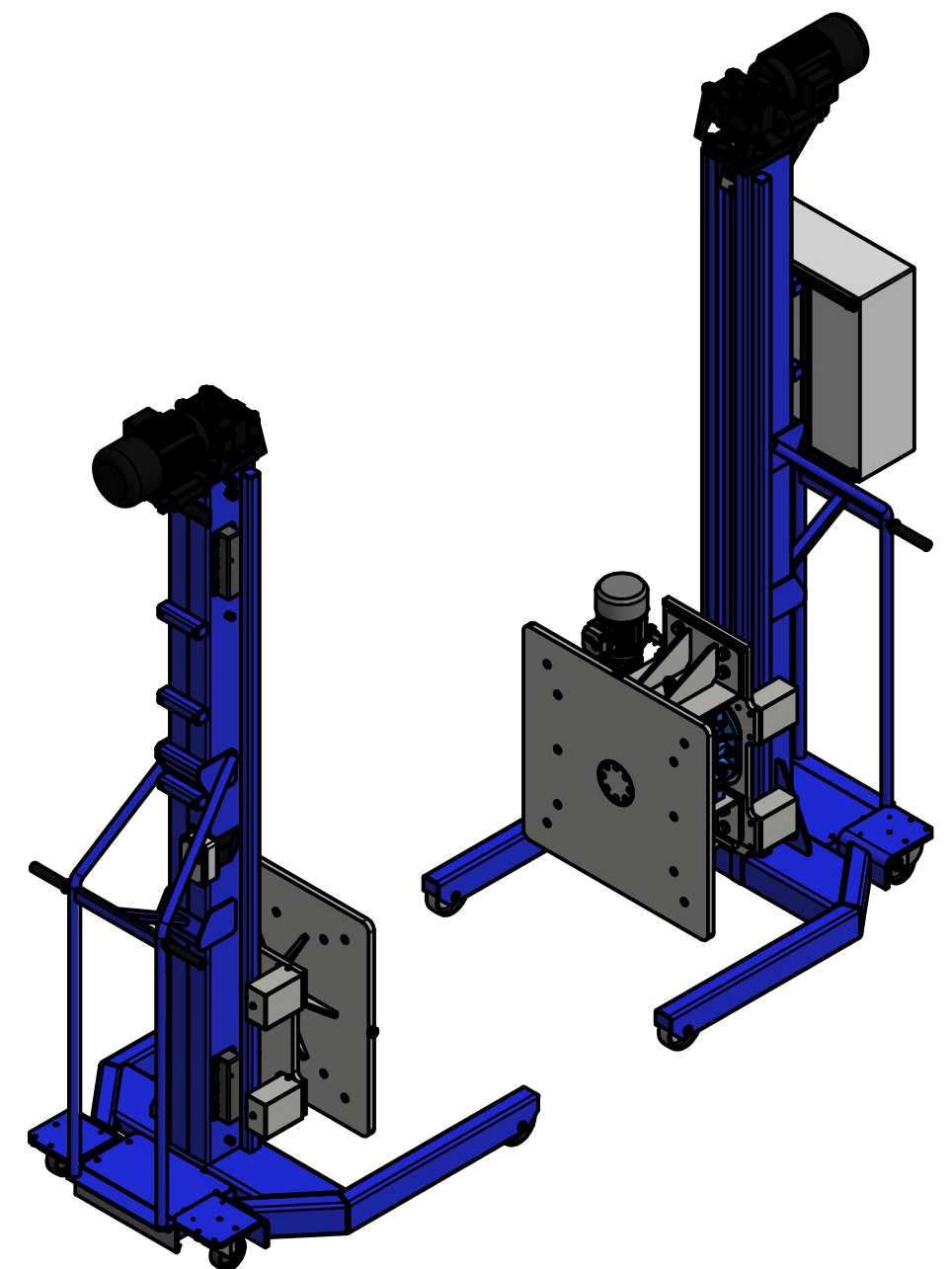

Standard flange plate
Standard Flanschplatte
Plaque à bride standard
(1 : 5)

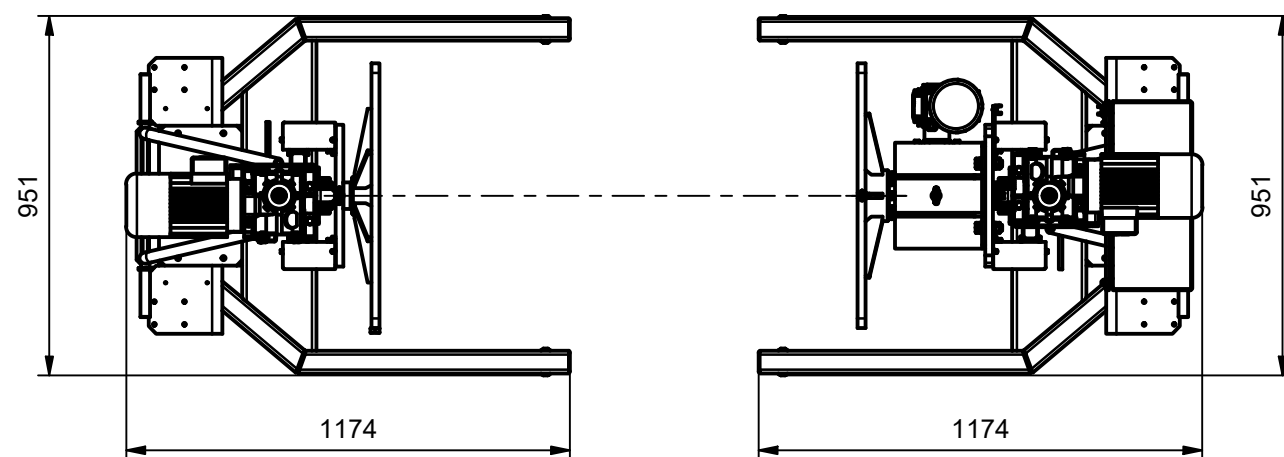
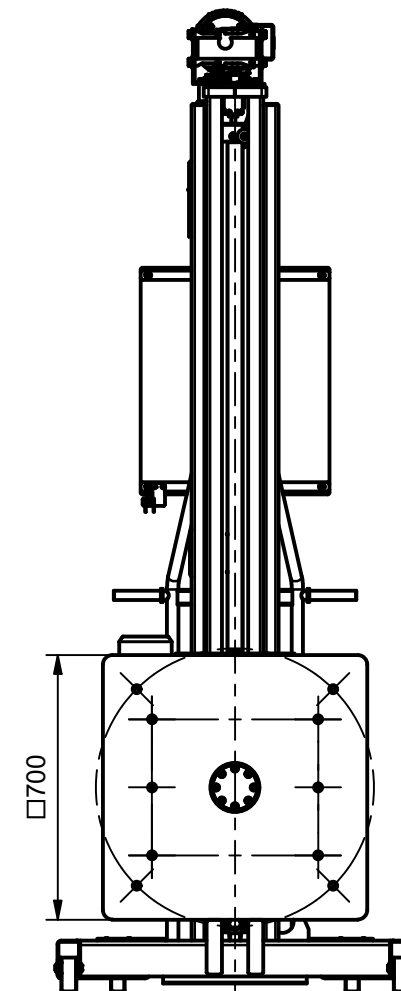
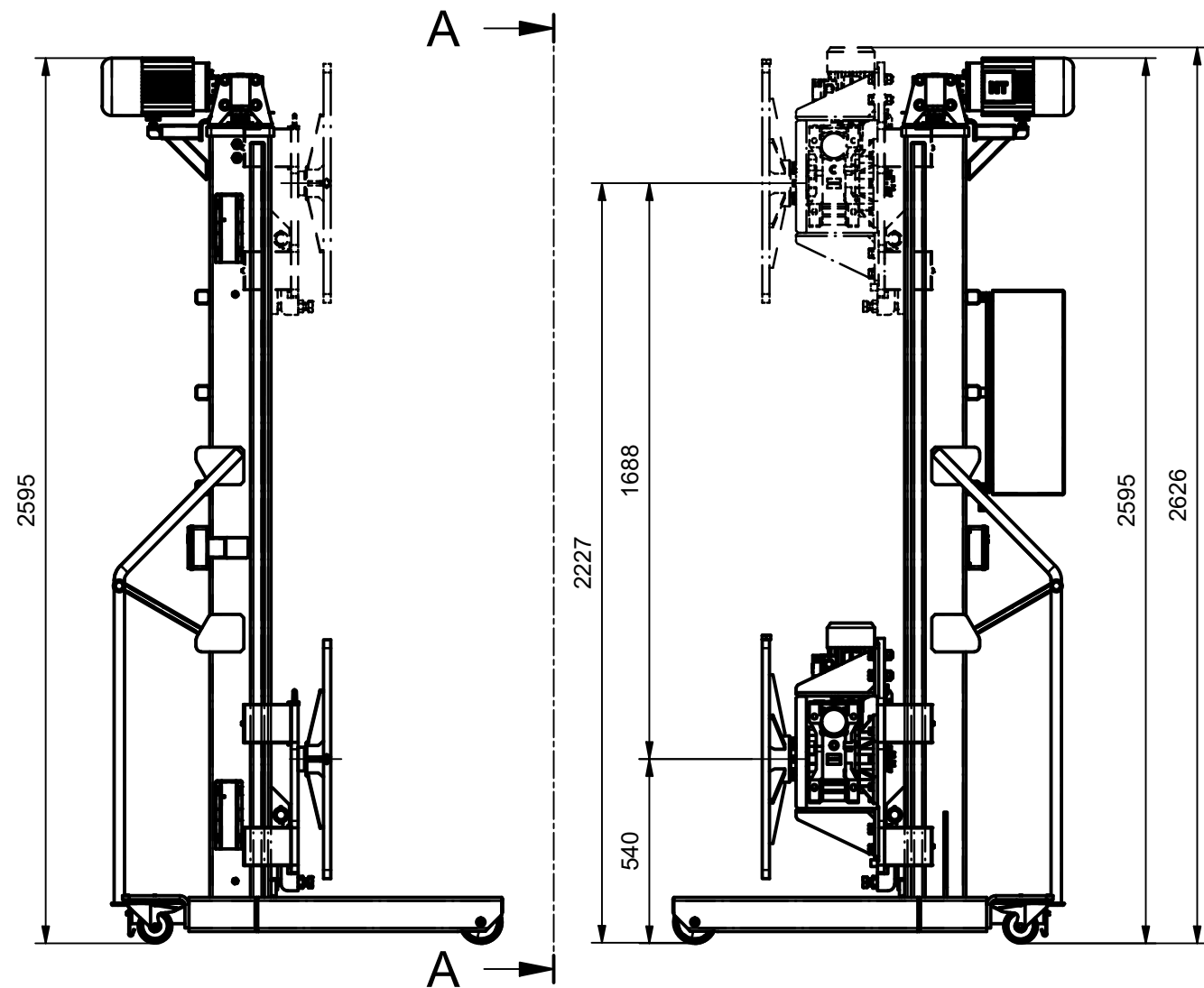
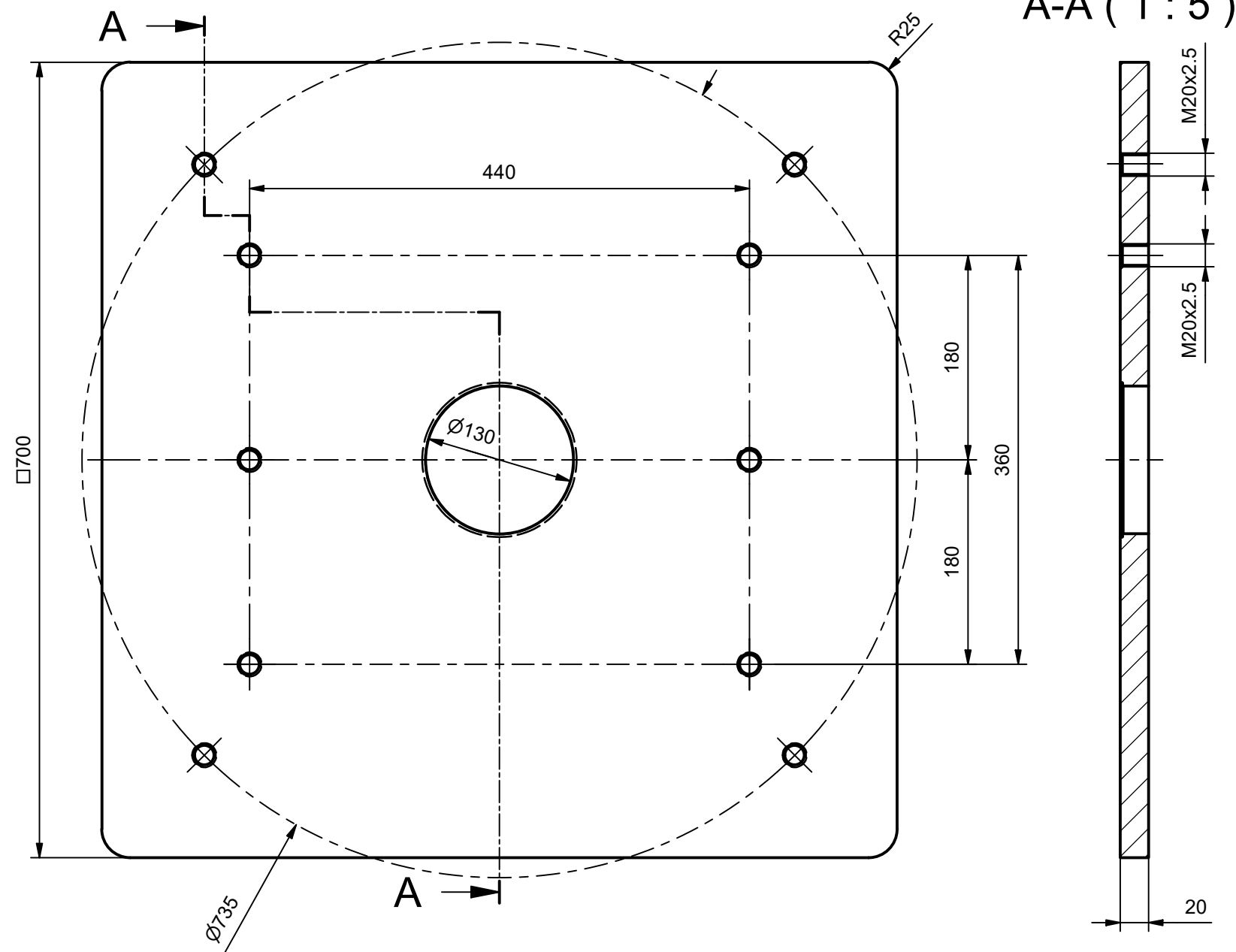

Leistungsdaten Performance data Caractéristiques	
DATA	WERT VALUE VALUER
Tragkraft Lifting capacity Capacité	2 x 1tons = 2tons
Drehmoment Turning moment Couple de rotation	2.000Nm
Hubgeschwindigkeit Lifting speed Vitesse de levage	770mm/min
Drehgeschwindigkeit Turning speed Vitesse de rotation	1,2rpm
Benötigte Leistung Required power Puissance requise	2 x 1,5kW 3 x 400V / 50Hz

